

# 20.2SS

FOR FASTENING SHEET TO PURLINS OF 1.2MM-3.5MM THICKNESS

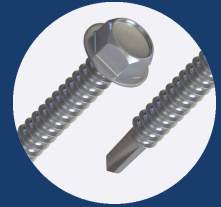

## PROPERTIES



MATERIAL	STAINLESS STEEL A2 - 304 GRADE
COATING	500 HRS (SILVER)
HEAD TYPE	HEX
DRILL POINT	2 PT
EFFECTIVE THREAD LENGTH	11.00
RECOMMENDED DRILL BIT/SOCKET	SOCKET-HEX-5/16"RING
RECOMMENDED DRILL SPEED	1500 - 2500 RPM

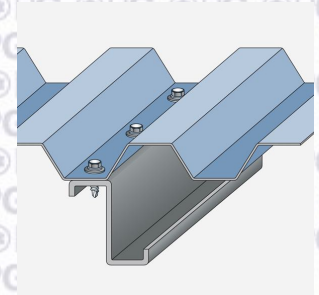

## PERFORMANCE

### PULL OUT



STEEL THICKNESS (MM)	1.20	1.60	2.00	2.50	3.00
VALUE (kN)	2.56	3.78	5.06	5.38	5.38

Grade of material: S450 Steel

### PULL OVER



WASHER	16MM x 2MM		19MM x 2MM	
SHEET THICKNESS (MM)	0.50	0.70	0.50	0.70
VALUE (kN)				

### SHEAR



VALUE (kN)	6.75
------------	------

### TENSILE



VALUE (kN)	5.38
------------	------

## DIMENSIONS

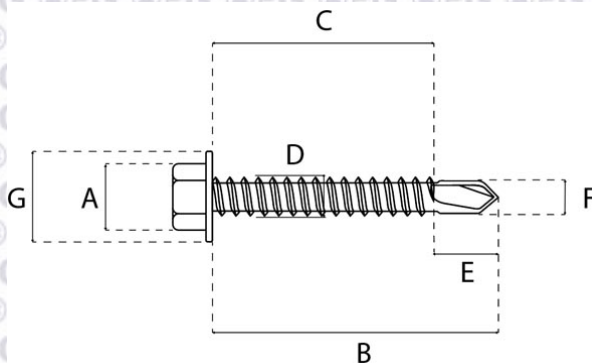

A (MM)	8.71
B (MM)	20.00
C (MM)	14.10
D (MM)	4.80
E (MM)	5.90
F (MM)	4.20
G (MM)	10.15