

25.2SSLPW(A4)

FOR FASTENING SHEET TO PURLINS OF 1.2MM-3.5MM THICKNESS

PROPERTIES



MATERIAL	STAINLESS STEEL A4 - 316 GRADE
COATING	BRIGHT ZINC PLATING
HEAD TYPE	LOW PROFILE
DRILL POINT	2 PT
EFFECTIVE THREAD LENGTH	16.00
RECOMMENDED DRILL BIT/SOCKET	BIT-T25
RECOMMENDED DRILL SPEED	1500 - 2500 RPM

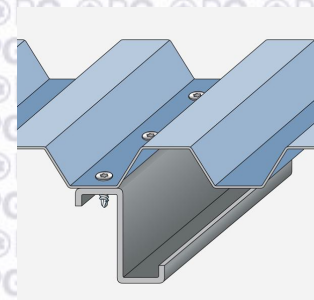

PERFORMANCE

PULL OUT

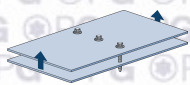

STEEL THICKNESS (MM)	1.20	1.60	2.00	2.50	3.00
VALUE (kN)	2.18	3.74	4.92	6.48	6.56

Grade of material: S450 Steel

PULL OVER



WASHER	16MM x 2MM		19MM x 2MM	
SHEET THICKNESS (MM)	0.50	0.70	0.50	0.70
VALUE (kN)				

SHEAR

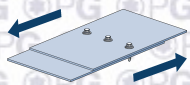

VALUE (kN)	6.50
------------	------

TENSILE

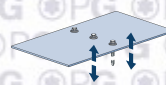

VALUE (kN)	8.14
------------	------

DIMENSIONS

A (MM)	14.50
B (MM)	25.00
C (MM)	19.10
D (MM)	5.50
E (MM)	5.90
F (MM)	4.50
G (MM)	N/A