

25.3SS

FOR FASTENING SHEET TO PURLINS OF 1.5MM-6MM THICKNESS

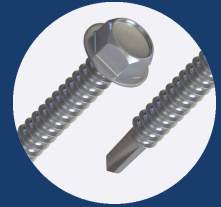

PROPERTIES



MATERIAL	STAINLESS STEEL A2 - 304 GRADE
COATING	500 HRS (SILVER)
HEAD TYPE	HEX
DRILL POINT	3 PT
EFFECTIVE THREAD LENGTH	15.00
RECOMMENDED DRILL BIT/SOCKET	SOCKET-HEX-5/16"RING
RECOMMENDED DRILL SPEED	1500 - 2500 RPM

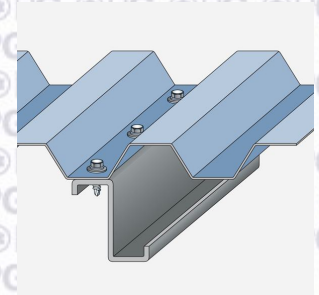

PERFORMANCE

PULL OUT



STEEL THICKNESS (MM)	2.00	4.00	6.00	N/A	N/A
VALUE (kN)	4.88	8.78	8.78		

Grade of material: S275 Steel

PULL OVER



WASHER	16MM x 2MM		19MM x 2MM	
SHEET THICKNESS (MM)	0.50	0.70	0.50	0.70
VALUE (kN)				

SHEAR



VALUE (kN)	9.02
------------	------

TENSILE

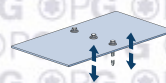

VALUE (kN)	8.78
------------	------

DIMENSIONS

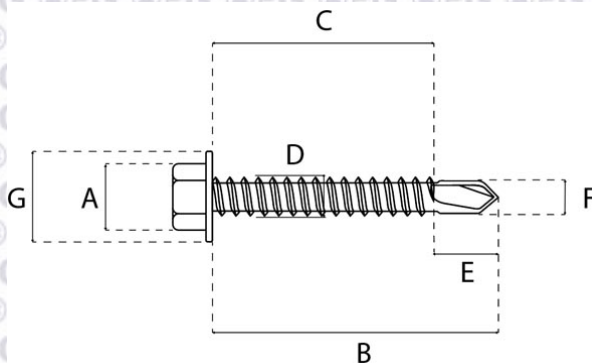

A (MM)	8.71
B (MM)	25.00
C (MM)	18.20
D (MM)	5.50
E (MM)	6.80
F (MM)	4.70
G (MM)	12.60