

25S

FOR FASTENING MAX 2 X 0.75MM SHEETS TO TIMBER



PROPERTIES



MATERIAL	CARBON STEEL
COATING	500 HRS (SILVER)
HEAD TYPE	HEX
DRILL POINT	GASH PT
EFFECTIVE THREAD LENGTH	20.00
RECOMMENDED DRILL BIT/SOCKET	SOCKET-HEX-5/16" MAG
RECOMMENDED DRILL SPEED	1500 - 2500 RPM

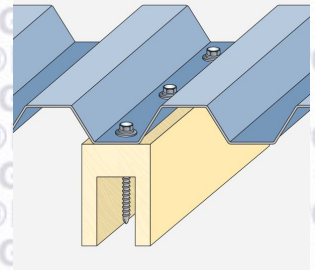

PERFORMANCE

PULL OUT

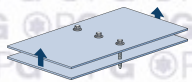

STEEL THICKNESS (MM)	15mm timber	25mm timber	35mm timber	N/A	N/A
VALUE (kN)	1.08	2.40	3.54		

Grade of material: C16 Timber

PULL OVER



WASHER	16MM x 2MM		19MM x 2MM	
SHEET THICKNESS (MM)	0.50	0.70	0.50	0.70
VALUE (kN)				

SHEAR

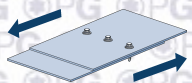

VALUE (kN)	9.60
------------	------

TENSILE

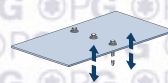

VALUE (kN)	20.90
------------	-------

DIMENSIONS

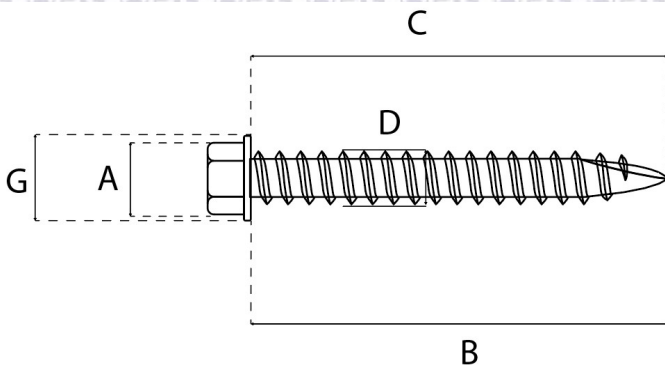

A (MM)	8.64
B (MM)	25.00
C (MM)	25.00
D (MM)	6.30
E (MM)	N/A
F (MM)	N/A
G (MM)	12.25